

We test, You produce

MS-50GT

LEAK TEST INSTRUMENT FOR ADVANCED LEAK METROLOGY

The **MS Series** of leak detectors represent the world's largest base of installed leak detectors which are fully automatic, easy to use, and highly accurate, these advanced design leak detectors are ideal for a broad range of applications including clean, oil-free testing.

Quality performance provides maximum productivity along with an ergonomically designed cabinet for operator comfort and viewing. Breakthrough technology combines high test port pressure, large capacity internal vacuum pumps, and ATEQ's unique mass spectrometer making the MS series leak detectors at least four times faster than conventional portable units available today.

BENEFITS

- Maximum performance
- Available with wet or dry pumping package
- Only production leak detector with a large interactive LCD touch screen display

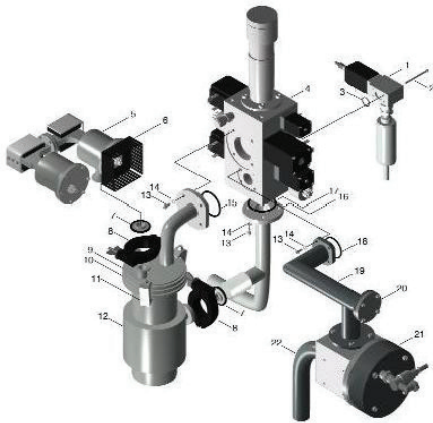

Vacuum System Assembly



Applications

Aerospace Components, Air Conditioning and Refrigeration Systems, Automotive Components and Appliances, Batteries, Electron Beam Welders, Electronics, Food Packaging, Hermetically Sealed Devices, Medical Products, Particle Accelerators, Pharmaceuticals, Power Distribution Plants, Semiconductors, Sputtering Equipment, Vacuum Systems, Valves...



MS-50GT

LEAK TEST INSTRUMENT

FOR ADVANCED LEAK METROLOGY

Measurement characteristics

- Sensitivity: 3×10^{-11} atm-cc/sec in direct mode, (3×10^{-12} w/MS-50 Dry HS unit)
- Sensitivity: 3×10^{-10} atm-cc/sec in reverse mode
- Sensitivity: 1×10^{-8} atm-cc/sec in sniff mode
- Leak Range: 10×10^{-9} to 3×10^{-11} atm-cc/sec
- Start Up Time: < 3 minutes
- Time To Test: < 1.5 seconds on a blank test port
- Response Time: Direct Mode <2 seconds, Reverse Mode <2.5 seconds
- Maximum Inlet Pressure: 100 Torr in Gross, 7.5 Torr in Fine
- Resolution: resolving power of 14 at mass 4
- Testable Masses: He 3 and He 4

Test Modes

- Flow Units: std cc/sec, mbar L/sec, Pa m³/sec (with helium or air equivalent units can be selected)
- Pressure Units: mTorr, mBar, Pa
- Leak Ranging: automatic and manual
- Testing Modes: Gross, Reverse, Direct, Combination, Sniff

Accessories

- Calibrated Gas Leaks
- Helium Bombing Station
- MS-50 Manual Backfill Station
- Connectors...

Options

- Handheld remote control unit with 25' or 50' cord
- External roughing kit, w/valving and manifolding and pump
- Mobile cart
- Mini Sniffer Probe
- UFT (Ultrafast Testing) Test Cups
- Cold Trap/Cold Finger
- Hard travel case

Other Formats

- MS-50GT Wet Pumping Package
- MS-50GT Dry Pumping Package
- MS-50GT Dual Port
- MS-50GT High Sense
- MS-50GT UFT
- MS-50 Argon
- MS-40 GT Portable Units featuring wet, dry, clean room, plus configurations

Main Features

- Simple one-button start up
- Fully automatic operation, tuning and calibration with internal NIST traceable temperature compensated calibrator
- Three modes of operation in a single unit along with a dedicated sniff mode
- Built-in diagnostics for trouble-free maintenance
- Dual magnetic sector mass spectrometer with resolving power of 14
- Dual pump system – dedicated foreline and roughing pumps
- Allows testing for the smallest leaks at the highest pressures
- High inlet pressure of 7.5 Torr provides fast time to test
- Ready to test in under three minutes
- Reduces operator training: easy to use
- Auto-zeroing with continuous background compensation
- Rotary vane and dry pumps available
- Faster, more accurate testing

Technical Specifications

Weight	215.45 lbs - 475 kg
Dimensions	Dimensions: (W x H x D): 65.40 x 77.79 x 89.54 inch 25.75 x 30.625 x 35.25 cm
Interface	Touch Screen Graphical User Controls
Electrical supply	115/50-60/30; 230-240/50-60/15; 100/50-60/30 (V/Hz/A)
Temperature	Operating: 32F to 115F / + 0°C to + 46°C Storage: 32F to 140F / + 0°C to + 60°C

